

LED Bulb installation manual (H4) Type

Article number : 341HLB(12V) 34VHLB(24V)

LED Bulb fitting

Space around the bulb

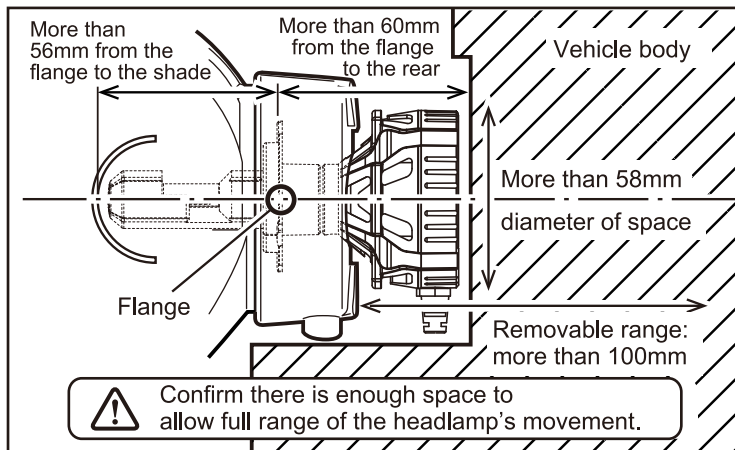

Direct contact with water, dirt or dust

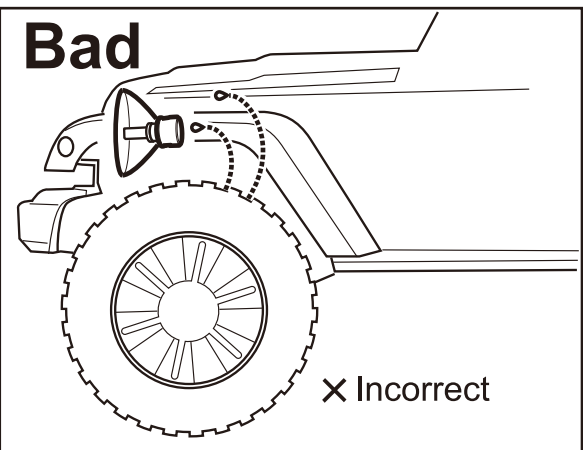

LED Bulb lighting test points

* Do it both bulbs before installation

<Test procedure>

1. Connect the new parts to the vehicle's connector.
2. Turn on the lamp both high beam and low beam. Test for correct lighting.
3. Check the high beam indicator lit normally on the dash.
4. Check the vehicles gauges for any warning sings. If no warnings, the test is finished.

Warning

Do not turn on the switch if the bulb is not connected.

Vehicle connector



LED Bulb connector (non-polarity)



Components

LED Bulb Assy ... 2

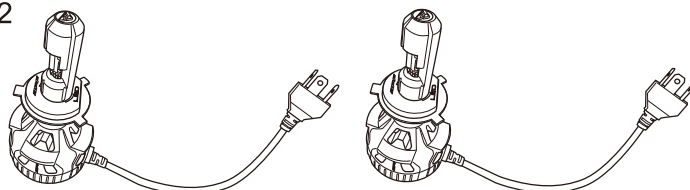

Protection tape ... 1



Installation procedure

1 Genuine bulb check

Check the condition of the bulb's attachment.

If the check cannot be done visually or the space is too narrow, please remove the headlamp unit from the vehicle.

2 Removing the bulb

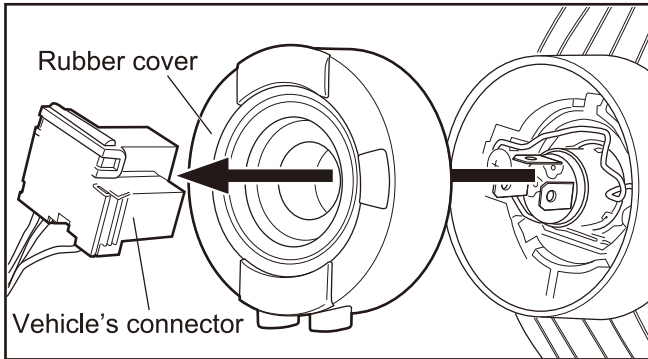

Remove the vehicle's connector and the rubber cover, unclasp and remove the bulb.

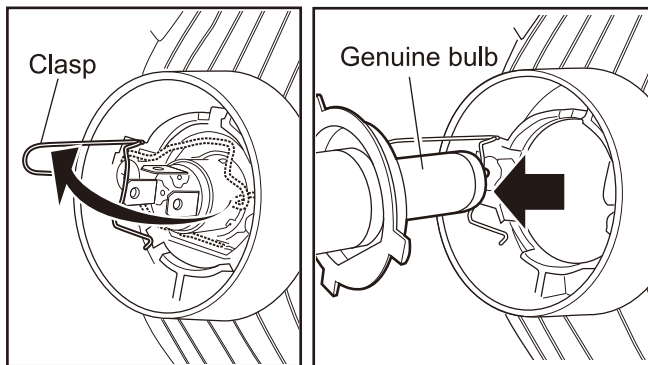

Refer to the vehicle's manual for bulb removal procedure, as it can differ between vehicles.

3 Preparing the bulb

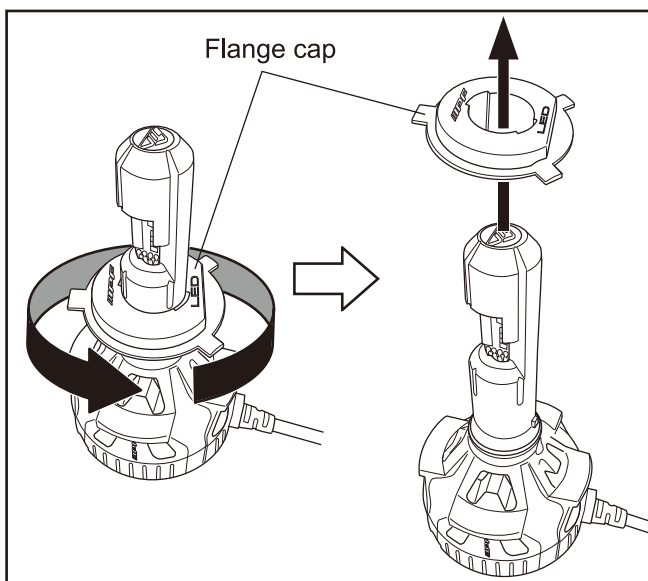

Remove the flange cap from the bulb. Refer to the figure left.

⚠ Caution

Wear work gloves to prevent a minor cut with pointed part of the bulb or flange.

4 Installing the bulb

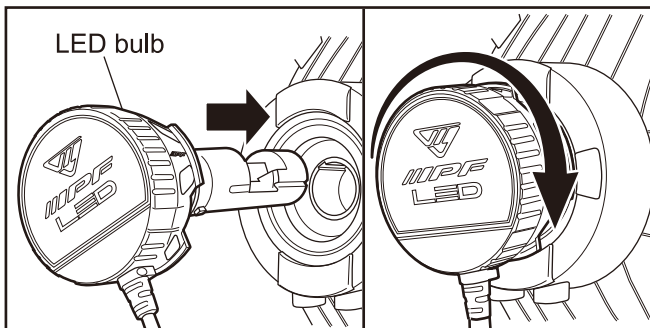
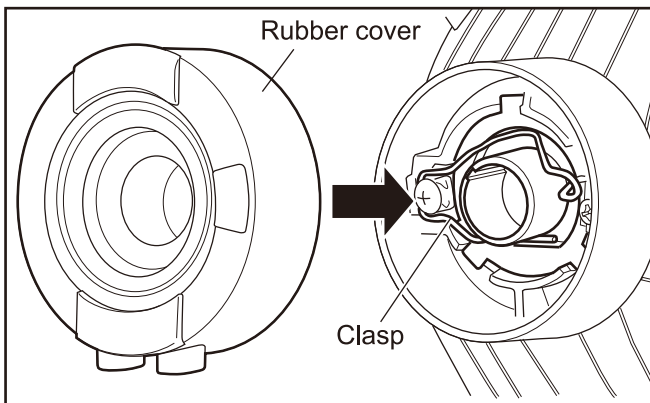
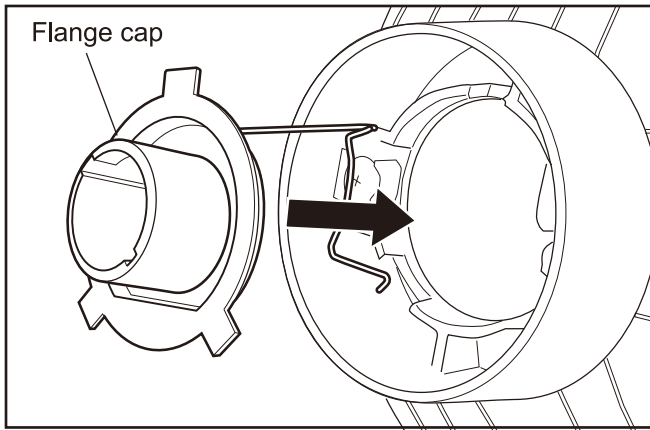

Attach and clasp the flange cap. Put the rubber cover back into place fit securely.

Guidance

Refer to the figure below. Verify that the flange cap is steady from side to side and up and down.
Use the protection tape if the attaching part is not steady.
Cut the protection tape in an appropriate size and apply it if necessary.

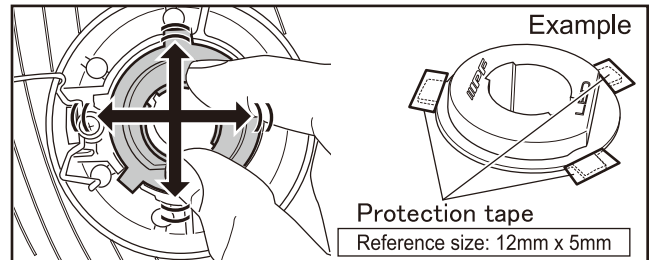

Caution

Verify that the flange cap and head lamp are secured. If loose it causes a damage to the bulb and head lamp rubbed by vehicle vibration.
Verify that the clasp is tightly secured.
To prevent water entry, push the rubber cover tightly around the center of the flange hole.

Insert the bulb straight deep into the flange cap. Rotate the bulb clockwise and secure tightly.

Warning

Insert the bulb straight cautiously into the flange cap.
Do not apply excessive force or use tools. It causes a damage to the bulb or head lamp.
Stop here if bulb does not fit without interference of other nearby objects.

5 Installation check

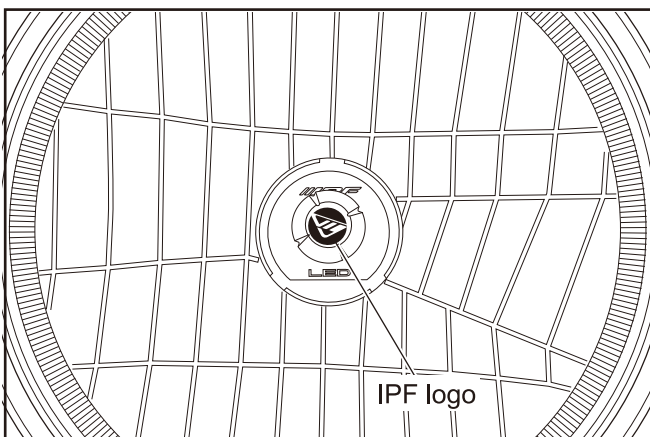

Verify that "IPF" & "LED" markings on the flange cap are horizontal as shown in the image left. When installing this product completed to a head lamp for right-hand traffic, "IPF logo" on back face of the bulb slant approximately 15 degrees, though this is in the right position.

(For left-hand traffic)

Verify that "IPF logo" on front edge of the bulb is horizontal. "IPF" & "LED" markings on the flange cap slant approximately 15 degrees, though this is in the right position.

6 Connecting the connector

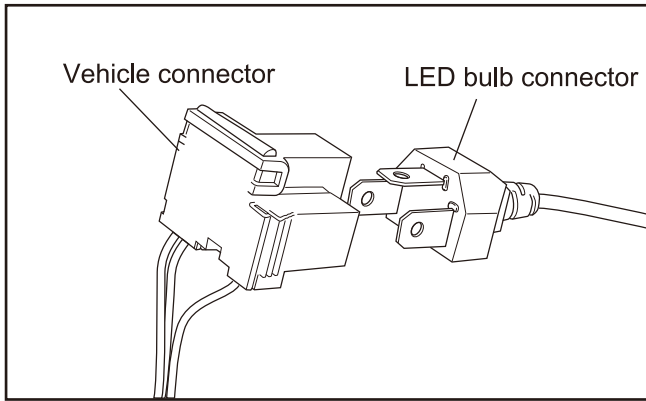

Connect the LED bulb connector with vehicle's connector, insert the connector all the way. If there is extra length in the harness, fix it into place with a standard cable tie, etc. Leave a little slack in the harness to give room for the movement of the headlamp leveler. If you removed the headlamp unit, reinstall the unit now.

⚠ Caution

If two connectors are not secured tightly, secure them with tape. A loose connection can short out the wiring.

Make sure to check connecting terminal and restore if needed

Repetitive connecting/disconnecting motion causes a bad fit of vehicle connector and LED bulb connector.

Check		<p>Check to see if the connection is workable. Connection should be restored in case that a male terminal lightly can fit in with a vehicle connector's terminal.</p> <p>*Check all three connections individually.</p>
-------	--	---

Restoration		<p>Restore the connecting terminal if loose and disconnected (see the figure left). Reduce the width of connecting point using a flat-blade screwdriver (precision screwdriver), etc.</p>
-------------	--	---

⚠ Warning

Remove the minus terminal when restoring connection. If using two batteries, remove both sides of the minus terminals.

7 Lighting check

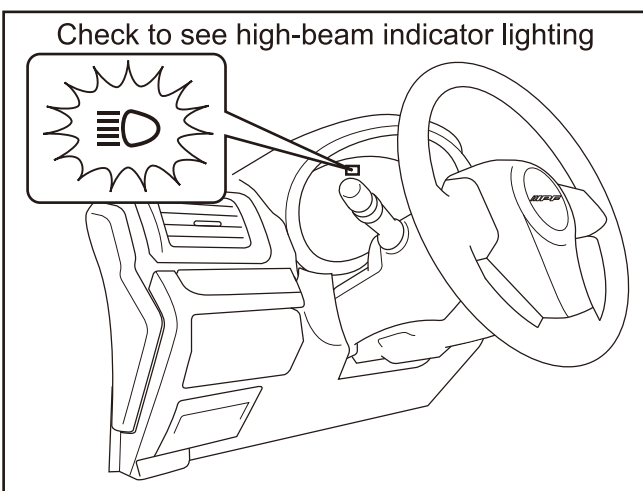

Turn on the engine. Switch on the headlamp. Check to see if both low-beam and high-beam light up properly. Check to see high-beam indicator lights up properly.

⚠ Headlight tester measurement caution points

Results might vary when using the auto mode with the headlight tester. Manual mode is recommended.